

A CLOSED-FORM APPROXIMATE SOLUTION FOR COUPLED VIBRATIONS OF COMPOSITE THIN-WALLED BEAMS WITH MID-PLANE SYMMETRY

Aleksandar Prokić, Radomir Folić, Ilija Miličić

Original scientific paper

The purpose of this paper is to develop and present an approximate analysis procedure to estimate the natural frequencies and mode shapes of thin-walled beams with arbitrary open cross-section, made of laminates with mid-plane symmetry. Theory of thin-walled composite beams is based on assumptions consistent with the Vlasov's beam theory and classical lamination theory. The equations of motion for coupled bending-torsional vibrations are derived from the principle of virtual displacements. In the case of simply supported thin-walled beam the frequency equation, given in determinant form, is expanded in an explicit analytical form, which gives the natural frequencies of free harmonic vibrations. For verification, the analytical study by other researchers and the FEM analysis using ANSYS are compared with the current results.

Keywords: approximate analytical solutions, classical lamination theory, explicit closed form, thin-walled composite beam, vibration

Analičko aproksimativno rješenje spregnutih vibracija kompozitnih tankostjenih greda simetričnih u odnosu na srednju plohu

Izvorni znanstveni članak

U radu je razvijen postupak i prikazana aproksimativna analiza za procjenu vlastitih frekvencija i oblika vibracija tankostjene grede s proizvoljnim poprečnim presjekom, izrađene od laminata simetričnih u odnosu na srednju plohu. Teorija kompozitnih tankostjenih greda zasniiva se na pretpostavkama suglasnim Vlasovljevoj teoriji greda i klasičnoj teoriji laminata. Jednadžbe gibanja za spregnute savojno-uvojne vibracije izvedene su iz principa virtualnih pomjeranja. Za prosto oslonjenu tankostjenu gredu jednadžba frekvencije, dana u obliku determinante, proširena je u eksplicitni analitički oblik za određivanje vlastitih frekvencija slobodnih harmonijskih vibracija. Radi potvrde predloženog modela, uspoređeni su analitički rezultati drugih autora i FEM metoda uporabom programa ANSYS, s rezultatima dobivenim u ovom radu.

Ključne riječi: aproksimativno analitičko rješenje, eksplicitno zatvoreno rješenje, klasična teorija laminata, tankostjena kompozitna greda, vibracije

1 Introduction

Thin-walled beams are widely used as structural elements in many types of structures. Compared to standard construction materials, composite materials present many advantages, e.g. light weight, corrosion resistance, low thermal expansion, and excellent fatigue characteristics in the direction of the fibers. To accurately predict the dynamic behavior of such constructions is an important part of engineering analysis.

Although a large amount of models have been developed to describe the behavior of composite thin-walled beams [1 ÷ 11], relatively fewer investigations are available that pertain to the vibration of laminated thin-walled beams [12 ÷ 17]. The accuracy of these models is strongly dependent on the different concepts and hypotheses used to formulate them. According to the authors' knowledge, there is no work in the literature studying coupled vibrations of composite thin-walled beams with arbitrary open cross-sections by means of an explicit closed-form solution.

The objective of this work is to develop an approximate analytical method for engineering practice that enables the prediction of natural frequencies of the free harmonic coupled vibrations of composite thin-walled beams with arbitrary open cross-sections accurately and efficiently. Mode shapes, which are coupled in bending and torsion, are expressed in explicit analytical form. The walls of the beam are symmetric laminates with different fiber orientations in different layers. The solution is limited to simply supported ends. The expressions are concise and very simple and as such convenient to be used by practicing engineer who does not need to go into detail of thin-walled beam theory. The method presented in this study is very useful for

pre-design purposes and also for verifying numerical results of complex and time-consuming computer procedures.

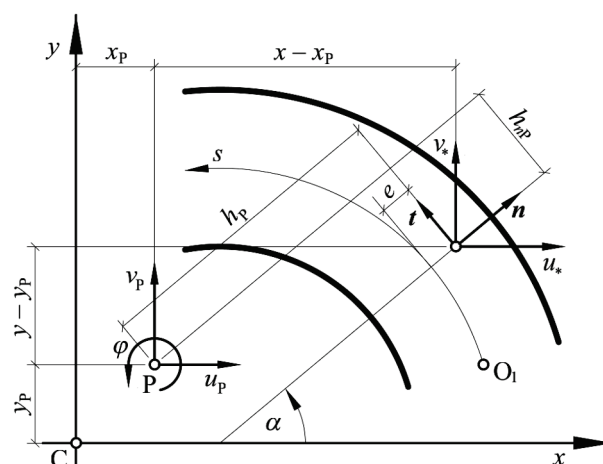

Figure 1 Coordinate system and geometric parameters of a beam

2 Theory

A straight thin-walled laminated composite beam of length l with an open cross-section is considered (Fig. 1). In order to determine the geometry of the cross-section of the beam two coordinate systems are used. The first of these is an orthogonal Cartesian coordinate system (x, y, z) for which the z -axis is parallel to the longitudinal axis of the beam. The second coordinate system is a local one (e, s, z) where e is the normal coordinate measured along the normal to contour (the midline of the cross-section) and s is profile coordinates measured along the contour line from arbitrarily taken starting point O_1 . The (e, s, z) and (x, y, z) coordinate systems are related through an

angle of orientation α . The coordinates of the contour in the (x, y, z) coordinate system are $(\bar{x}, \bar{y}, \bar{z})$. Point P , with coordinates x_P and y_P with respect to the reference coordinate system, is called the pole.

2.1 Kinematics of the beam

Following Vlasov's beam theory the following assumptions are made:

- The cross-section of the beam is not distorted during the deformation of the beam.
- The shear strains in the middle surface of the wall are negligible.
- The Kirchhoff-Love assumption in classical plate theory remains valid for laminated composite thin-walled beams.
- Each element is symmetric with respect to its mid-plane

Based on assumption above, the displacements u_* , v_* and w_* at any point on the beam cross-section can be expressed by only four components, two translations u_P , v_P of arbitrarily taken pole P , the cross-section rotation φ about the pole P , and axial displacement w of centroid

$$\begin{aligned} u_* &= u_P - (y - y_P)\varphi, \\ v_* &= v_P + (x - x_P)\varphi, \\ w_* &= w - u'_P x - v'_P y - \varphi' \omega_P, \end{aligned} \tag{1}$$

where ω_P

$$\omega_P = \int_0^s h_P ds + h_{nP} e, \tag{2}$$

is generalized warping function with regard to pole P . In Eq. (1) the prime denotes the differentiation with respect to z .

h_P and h_{nP} , perpendicular distance from tangent and normal at arbitrary point of cross-section to the point P , are positive when normal \vec{n} and tangent \vec{t} , respectively, are rotating counterclockwise about the pole P , when observed from the positive z direction. The second term on the right-hand side of Eq. (2) determines the relative warping in relation to the midline of cross-section.

Consistent with displacement field, Eq. (1), the non-vanishing strain components are

$$\begin{aligned} \epsilon_z &= w' - u''_P x - v''_P y - \varphi'' \omega_P, \\ \gamma_{sz} &= 2\varphi' e. \end{aligned} \tag{3}$$

2.2 Constitutive equations

The constitutive equations of a k -th unidirectionally reinforced lamina in the s - z co-ordinate system are given by

$$\begin{bmatrix} \sigma_z \\ \sigma_s \\ \tau_{sz} \end{bmatrix}_k = \begin{bmatrix} \bar{Q}_{11} & \bar{Q}_{12} & \bar{Q}_{16} \\ \bar{Q}_{12} & \bar{Q}_{22} & \bar{Q}_{26} \\ \bar{Q}_{16} & \bar{Q}_{26} & \bar{Q}_{66} \end{bmatrix}_k \begin{bmatrix} \epsilon_z \\ \epsilon_s \\ \gamma_{sz} \end{bmatrix}, \tag{4}$$

where the terms \bar{Q}_{ij} are transformed reduced stiff nesses for a plane stress state, Jones [21].

By using free stress in contour direction, $\sigma_s = 0$, the above equation can be simplified as

$$\begin{bmatrix} \sigma_z \\ \tau_s \end{bmatrix}_k = \begin{bmatrix} \bar{Q}_{11} & \bar{Q}_{16} \\ \bar{Q}_{16} & \bar{Q}_{66} \end{bmatrix}_k \begin{bmatrix} \epsilon_z \\ \gamma_{zs} \end{bmatrix}, \tag{5}$$

where

$$\begin{aligned} \bar{Q}_{11} &= \bar{Q}_{11} - \frac{\bar{Q}_{12}^2}{\bar{Q}_{22}}, \\ \bar{Q}_{16} &= \bar{Q}_{16} - \frac{\bar{Q}_{12}\bar{Q}_{26}}{\bar{Q}_{22}}, \\ \bar{Q}_{66} &= \bar{Q}_{66} - \frac{\bar{Q}_{26}^2}{\bar{Q}_{22}}, \end{aligned} \tag{6}$$

Stress resultants at the cross-section can be derived by integrating the corresponding stresses over the cross sectional area, as given by

$$\begin{aligned} N &= \iint_A \sigma_z dA, \\ M_x &= \iint_A \sigma_z y dA, \\ M_y &= -\iint_A \sigma_z x dA, \\ M_{\omega_P} &= \iint_A \sigma_z \omega_P dA, \\ T_s &= 2 \iint_A \tau_s e dA. \end{aligned} \tag{7}$$

In Eq. (7), N represents the axial force, M_x and M_y the bending moments with respect to the x and y axis, T_s the Saint Venant torque, M_{ω_P} the bimoment and F the area of the cross-section. Combining Eqs. (3), (5) and (7) the forces may be defined in terms of componential displacements as

$$\begin{aligned} N &= \iint_A [\bar{Q}_{11}(w' - u''_P x - v''_P y - \varphi'' \omega_P) + \bar{Q}_{16} 2\varphi' e] dA, \\ M_x &= \iint_A [\bar{Q}_{11}(w' - u''_P x - v''_P y - \varphi'' \omega_P)y + \bar{Q}_{16} 2\varphi' e y] dA, \\ M_y &= -\iint_A [\bar{Q}_{11}(w' - u''_P x - v''_P y - \varphi'' \omega_P)x + \bar{Q}_{16} 2\varphi' e x] dA, \\ M_{\omega_P} &= \iint_A [\bar{Q}_{11}(w' - u''_P x - v''_P y - \varphi'' \omega_P)\omega_P + \bar{Q}_{16} 2\varphi' e \omega_P] dA, \\ T_s &= 2 \iint_A [\bar{Q}_{16}(w' - u''_P x - v''_P y - \varphi'' \omega_P)e + \bar{Q}_{66} 2\varphi' e^2] dA, \end{aligned} \tag{8}$$

or written in matrix form

$$\begin{bmatrix} N \\ M_y \\ -M_x \\ -M_{\omega_P} \\ T_s \end{bmatrix} = \begin{bmatrix} A^c & -S_x^c & -S_y^c & -S_{\omega_P}^c & S_e^c \\ -S_x^c & I_{xx}^c & I_{xy}^c & I_{x\omega_P}^c & -I_{xe}^c \\ -S_y^c & I_{xy}^c & I_{yy}^c & I_{y\omega_P}^c & -I_{ye}^c \\ -S_{\omega_P}^c & I_{x\omega_P}^c & I_{y\omega_P}^c & I_{\omega_P\omega_P}^c & -I_{\omega_P e}^c \\ S_e^c & -I_{xe}^c & -I_{ye}^c & -I_{\omega_P e}^c & I_{ee}^c \end{bmatrix} \begin{bmatrix} w' \\ v'_P \\ u'_P \\ \varphi'' \\ \varphi' \end{bmatrix}. \tag{9}$$

The sectional quantities in Eq. (9) are defined as a function of the geometry and material properties of cross-section.

$$\begin{aligned}
 A^c &= \iint_A \bar{Q}_{11} dA = \int_S A_{11} ds, \\
 S_x^c &= \iint_A \bar{Q}_{11} x dA = \int_S (A_{11} \bar{x} + B_{11} \cos \alpha) ds, \\
 S_y^c &= \iint_A \bar{Q}_{11} y dA = \int_S (A_{11} \bar{y} + B_{11} \sin \alpha) ds, \\
 S_{\omega_P}^c &= \iint_A \bar{Q}_{11} \omega_P dA = \int_S (A_{11} \bar{\omega}_P + B_{11} h_{nP}) ds, \\
 I_{xx}^c &= \iint_A \bar{Q}_{11} x^2 dA = \int_S (A_{11} \bar{x}^2 + 2B_{11} \bar{x} \cos \alpha + D_{11} \cos^2 \alpha) ds, \\
 I_{yy}^c &= \iint_A \bar{Q}_{11} y^2 dA = \int_S (A_{11} \bar{y}^2 + 2B_{11} \bar{y} \sin \alpha + D_{11} \sin^2 \alpha) ds, \\
 I_{xy}^c &= \iint_A \bar{Q}_{11} xy dA = \int_S [A_{11} \bar{x} \bar{y} + B_{11} (\bar{x} \sin \alpha + \bar{y} \cos \alpha) + D_{11} \sin \alpha \cos \alpha] ds, \\
 I_{x\omega_P}^c &= \iint_A \bar{Q}_{11} \omega_P x dA = \int_S [A_{11} \bar{x} \bar{\omega}_P + B_{11} (\bar{x} h_{nP} + \bar{\omega}_P \cos \alpha) + D_{11} h_{nP} \cos \alpha] ds, \\
 I_{y\omega_P}^c &= \iint_A \bar{Q}_{11} \omega_P y dA = \int_S [A_{11} \bar{y} \bar{\omega}_P + B_{11} (\bar{y} h_{nP} + \bar{\omega}_P \sin \alpha) + D_{11} h_{nP} \sin \alpha] ds, \\
 I_{\omega_P \omega_P}^c &= \iint_A \bar{Q}_{11} \omega_P^2 dA = \int_S (A_{11} \bar{\omega}_P^2 + 2B_{11} \bar{\omega}_P h_{nP} + D_{11} h_{nP}^2) ds, \\
 S_e^c &= 2 \iint_A \bar{Q}_{16} e dA = 2 \int_S B_{16} ds, \\
 I_{xe}^c &= 2 \iint_A \bar{Q}_{16} x e dA = 2 \int_S (B_{16} \bar{x} + D_{16} \cos \alpha) ds, \\
 I_{ye}^c &= 2 \iint_A \bar{Q}_{16} y e dA = 2 \int_S (B_{16} \bar{y} + D_{16} \sin \alpha) ds, \\
 I_{\omega_P e}^c &= 2 \iint_A \bar{Q}_{16} \omega_P e dA = 2 \int_S (B_{16} \bar{\omega}_P + D_{16} h_{nP}) ds, \\
 I_{ee}^c &= 4 \iint_A \bar{Q}_{66} e^2 dA = 4 \int_S D_{66} ds,
 \end{aligned} \tag{10}$$

where

$$\begin{aligned}
 x &= \bar{x} + e \cdot \cos \alpha, \\
 y &= \bar{y} + e \cdot \sin \alpha, \\
 \omega_P &= \bar{\omega}_P + h_{nP} \cdot e,
 \end{aligned} \tag{11}$$

and

$$\begin{aligned}
 A_{ij} &= \int \bar{Q}_{ij} de, \\
 B_{ij} &= \int \bar{Q}_{ij} e de, \\
 D_{ij} &= \int \bar{Q}_{ij} e^2 de.
 \end{aligned} \tag{12}$$

By appropriate selection of Cartesian coordinate system, pole P and starting point O₁ we can achieve that

$$\begin{aligned}
 S_x^c &= S_y^c = I_{xy}^c = 0, \\
 S_{\omega_P}^c &= I_{x\omega_P}^c = I_{y\omega_P}^c = 0,
 \end{aligned} \tag{13}$$

So, introducing ideal center of gravity and shear center D, we get the simplified expressions for stress resultants.

$$\begin{bmatrix} N \\ M_y \\ -M_x \\ -M_{\omega_D} \\ T_s \end{bmatrix} = \begin{bmatrix} A^c & 0 & 0 & 0 & S_e^c \\ 0 & I_{xx}^c & 0 & 0 & -I_{xe}^c \\ 0 & 0 & I_{yy}^c & 0 & -I_{ye}^c \\ 0 & 0 & 0 & I_{\omega_D \omega_D}^c & -I_{\omega_D e}^c \\ S_e^c & -I_{xe}^c & -I_{ye}^c & -I_{\omega_D e}^c & I_{ee}^c \end{bmatrix} \cdot \begin{bmatrix} w'_D \\ u''_D \\ v''_D \\ \varphi'' \\ \varphi' \end{bmatrix}, \tag{14}$$

$$\begin{aligned}
 &\begin{bmatrix} A^c & 0 & 0 & 0 \\ 0 & I_{xx}^c & 0 & 0 \\ 0 & 0 & I_{yy}^c & 0 \\ 0 & 0 & 0 & I_{\omega_D \omega_D}^c \end{bmatrix} \begin{bmatrix} w''''_D \\ u''''_D \\ v''''_D \\ \varphi'''' \end{bmatrix} + \begin{bmatrix} 0 & 0 & 0 & S_e^c \\ 0 & 0 & 0 & -I_{xe}^c \\ 0 & 0 & 0 & -I_{ye}^c \\ -S_e^c & I_{xe}^c & I_{ye}^c & 0 \end{bmatrix} \begin{bmatrix} w''_D \\ u''_D \\ v''_D \\ \varphi'' \end{bmatrix} - \begin{bmatrix} 0 & 0 & 0 & 0 \\ 0 & 0 & 0 & 0 \\ 0 & 0 & 0 & 0 \\ 0 & 0 & 0 & I_{ee}^c \end{bmatrix} \begin{bmatrix} w'_D \\ u''_D \\ v''_D \\ \varphi'' \end{bmatrix} - \\
 &-\rho \begin{bmatrix} A & -S_x & -S_y & -S_{\omega_D} \\ -S_x & I_{xx} & I_{xy} & I_{x\omega_D} \\ -S_y & I_{xy} & I_{yy} & I_{y\omega_D} \\ -S_{\omega_D} & I_{x\omega_D} & I_{y\omega_D} & I_{\omega_D \omega_D} \end{bmatrix} \begin{bmatrix} \ddot{w}_D \\ \ddot{u}_D \\ \ddot{v}_D \\ \ddot{\varphi} \end{bmatrix} + \rho \begin{bmatrix} 0 & 0 & 0 & 0 \\ 0 & A & 0 & y_D A - S_y \\ 0 & 0 & A & -x_D A + S_x \\ 0 & y_D A - S_y & -x_D A + S_x & I_D \end{bmatrix} \begin{bmatrix} \ddot{w}_D \\ \ddot{u}_D \\ \ddot{v}_D \\ \ddot{\varphi} \end{bmatrix} = \begin{bmatrix} -p'_z \\ p_x - m'_y \\ p_y + m'_x \\ m_D + m'_{\omega_D} \end{bmatrix},
 \end{aligned} \tag{16}$$

where

$$\begin{aligned}
 S_x &= \iint_A x dA; \quad S_y = \iint_A y dA; \quad S_{\omega_D} = \iint_A \omega_D dA, \\
 I_{xx} &= \iint_A x^2 dA; \quad I_{yy} = \iint_A y^2 dA; \quad I_{xy} = \iint_A xy dA, \\
 I_{x\omega_P} &= \iint_A x \omega_P dA; \quad I_{y\omega_P} = \iint_A y \omega_P dA;
 \end{aligned} \tag{17}$$

2.3 Equations of motion and free vibration analysis

Using the principle of virtual work the following four equations are obtained, Prokić [19] and [20].

$$\begin{aligned}
 N' - \rho \iint_A \ddot{w}_* dA + p_z &= 0, \\
 M''_y + \rho \iint_A x \ddot{w}_* dA + \rho \iint_A \ddot{u}_* dA - p_x + m'_y &= 0, \\
 M''_x - \rho \iint_A y \ddot{w}_* dA - \rho \iint_A \ddot{v}_* dA + p_y + m'_x &= 0, \\
 M''_{\omega_D} + T'_s - \rho \iint_A \omega_D \ddot{w}_* dA + \\
 + \rho \iint_A [(y - y_D) \ddot{u}_* - (x - x_D) \ddot{v}_*] dA + m_D + m'_{\omega_D} &= 0,
 \end{aligned} \tag{15}$$

where p_x , p_y , m_x , m_y , m_D and m_{ω_D} represent external distributed loads per unit length in x and y directions, externally applied distributed moments per unit length about x , y and z axes, and external distributed warping moment (bimoment), respectively.

The Equations of motion can be obtained in matrix form, by substituting for the stress resultants from (14) into (15), with generalized displacements as primary unknowns

$$I_{\omega_D \omega_D} = \iint_A \omega_D^2 dA,$$

$$I_D = \iint_A [(x - x_D)^2 + (y - y_D)^2] dA.$$

To achieve the compact form we artificially raise the order of Eq. (16–1) by one.

If we now examine the expressions for I_{xe}^c and I_{ye}^c

$$\begin{aligned}
 I_{x_e}^c &= 2 \int_s (B_{16}\bar{x} + D_{16}\cos\alpha) ds, \\
 I_{y_e}^c &= 2 \int_s (B_{16}\bar{y} + D_{16}\sin\alpha) ds,
 \end{aligned}
 \tag{18}$$

we can assume that the second terms on the r.h.s. of Eq. (18) are, in general, negligible as compared to the first one.

Introducing this simplifying assumption we neglect the change of point coordinates along the wall thickness that is, we adopt their mean value. It is justified since the wall thickness is small enough compared with the dimensions of the cross section. Also, according to initial assumption each laminate is symmetric about its mid-plane, thus all the coupling terms B_{ij} are zero, so we can write

$$\begin{aligned}
 S_\varepsilon^c &= 0, \\
 I_{x_e}^c &= 0, \\
 I_{y_e}^c &= 0,
 \end{aligned}
 \tag{19}$$

$$\begin{aligned}
 &\begin{bmatrix} A^c & 0 & 0 & 0 \\ 0 & I_{xx}^c & 0 & 0 \\ 0 & 0 & I_{yy}^c & 0 \\ 0 & 0 & 0 & I_{\omega_D\omega_D}^c \end{bmatrix} \begin{bmatrix} w'''' \\ u''''_D \\ v''''_D \\ \varphi'''' \end{bmatrix} - \begin{bmatrix} 0 & 0 & 0 & 0 \\ 0 & 0 & 0 & 0 \\ 0 & 0 & 0 & 0 \\ 0 & 0 & 0 & I_{ee}^c \end{bmatrix} \begin{bmatrix} w' \\ u'_D \\ v'_D \\ \varphi'' \end{bmatrix} - \\
 &-\rho \begin{bmatrix} A & 0 & 0 & 0 \\ 0 & I_{xx} & I_{xy} & I_{x\omega_D} \\ 0 & I_{xy} & I_{yy} & I_{y\omega_D} \\ 0 & I_{x\omega_D} & I_{y\omega_D} & I_{\omega_D\omega_D} \end{bmatrix} \begin{bmatrix} \ddot{w}' \\ \ddot{u}'_D \\ \ddot{v}'_D \\ \ddot{\varphi}'' \end{bmatrix} + \rho \begin{bmatrix} 0 & 0 & 0 & 0 \\ 0 & A & 0 & y_D A \\ 0 & 0 & A & -x_D A \\ 0 & y_D A & -x_D A & I_D \end{bmatrix} \begin{bmatrix} \ddot{w} \\ \ddot{u}_D \\ \ddot{v}_D \\ \ddot{\varphi} \end{bmatrix} = \begin{bmatrix} -p'_z \\ p_x - m'_y \\ p_y + m'_x \\ m_D + m'_{\omega_D} \end{bmatrix}.
 \end{aligned}
 \tag{21}$$

The first equation in (21), describing axial vibration, is uncoupled from the rest of the system and may be analyzed independently.

The free harmonic transverse and torsional vibrations are defined by the coupled homogeneous Eq. (21, 22, 23, 24). In the case of a beam with simply supported ends (fork supports at each end which prevent rotation and can warp freely) the end conditions are

$$[u_D \quad v_D \quad \varphi \quad u''_D \quad v''_D \quad \varphi''] = 0.
 \tag{22}$$

$$\left(\lambda_n^4 \begin{bmatrix} I_{xx}^c & & & \\ & I_{yy}^c & & \\ & & I_{\omega_D\omega_D}^c & \\ & & & \end{bmatrix} + \lambda_n^2 \begin{bmatrix} 0 & 0 & 0 \\ 0 & 0 & 0 \\ 0 & 0 & I_{ee}^c \end{bmatrix} - \lambda_n^2 \rho p^2 \begin{bmatrix} I_{xx} & I_{xy} & I_{x\omega_D} \\ I_{xy} & I_{yy} & I_{y\omega_D} \\ I_{x\omega_D} & I_{y\omega_D} & I_{\omega_D\omega_D} \end{bmatrix} - \rho A p^2 \begin{bmatrix} 1 & 0 & y_D \\ 0 & 1 & -x_D \\ y_D & -x_D & \frac{I_D}{A} \end{bmatrix} \right) \begin{bmatrix} C_u \\ C_v \\ C_\varphi \end{bmatrix} = \begin{bmatrix} 0 \\ 0 \\ 0 \end{bmatrix}.
 \tag{24}$$

Setting the determinant of the above system equal to zero

$$\begin{vmatrix} \lambda_n^4 I_{xx}^c - (\lambda_n^2 I_{xx} + A) p_* & -\lambda_n^2 I_{xy} p_* & -(\lambda_n^2 I_{x\omega_D} + y_D A) p_* \\ -\lambda_n^2 I_{xy} p_* & \lambda_n^4 I_{yy}^c - (\lambda_n^2 I_{yy} + A) p_* & -(\lambda_n^2 I_{y\omega_D} - x_D A) p_* \\ -(\lambda_n^2 I_{x\omega_D} + y_D A) p_* & -(\lambda_n^2 I_{y\omega_D} - x_D A) p_* & \lambda_n^4 I_{\omega_D\omega_D}^c + \lambda_n^2 I_{ee}^c - (\lambda_n^2 I_{\omega_D\omega_D} + I_D) p_* \end{vmatrix} = 0.
 \tag{25}$$

where

$$p_* = \rho p^2,
 \tag{26}$$

yields the following algebraic frequency equation

$$ap_*^3 + bp_*^2 + cp_* + d = 0.
 \tag{27}$$

If all laminates are equal, with the laminas arranged symmetrically about the middle surface of the laminate, from both a geometric and a material property standpoint, then center of gravity coincides with ideal center of gravity D , i.e.

$$\begin{aligned}
 S_x^c &= S_x = 0, \\
 S_y^c &= S_y = 0, \\
 S_{\omega_D}^c &= S_{\omega_D} = 0.
 \end{aligned}
 \tag{20}$$

Now, taking into account (19) and (20), matrix equation (16) becomes form (21), i.e.

The solution may be expressed in the form

$$\begin{bmatrix} u_D(z, t) \\ v_D(z, t) \\ \varphi(z, t) \end{bmatrix} = \begin{bmatrix} C_u \\ C_v \\ C_\varphi \end{bmatrix} \sin \lambda_n z \sin p t,
 \tag{23}$$

where p is the radian frequency, $\lambda_n = n\pi/L, n=1,2,\dots$ and C_u, C_v and C_φ are unknown constants.

Substituting (23) into homogeneous Eq. (21) yields

The coefficients a, b, c and d are given in Appendix.

For every n , from Eq. (27), three natural frequencies p_{*i} ($i = 1, 2$ and 3) of a simply supported beam are derived.

Substituting p_{*i} into Eq. (24) the three vectors C may be determined to the multiplicative constant factor.

$$C_i = \begin{bmatrix} C_u \\ C_v \\ C_\varphi \end{bmatrix}_i = \begin{bmatrix} 1 \\ \frac{[\lambda_n^4 I_{xx}^c - (\lambda_n^2 I_{xx} + A)p_{*i}](\lambda_n^2 I_{y\omega_D} - x_D A)p_{*i} + (\lambda_n^2 I_{x\omega_D} + y_D A)\lambda_n^2 I_{xy} p_{*i}^2}{[\lambda_n^4 I_{yy}^c - (\lambda_n^2 I_{yy} + A)p_{*i}](\lambda_n^2 I_{x\omega_D} + y_D A)p_{*i} + (\lambda_n^2 I_{y\omega_D} - x_D A)\lambda_n^2 I_{xy} p_{*i}^2} \\ \frac{[\lambda_n^4 I_{xx}^c - (\lambda_n^2 I_{xx} + A)p_{*i}][\lambda_n^4 I_{yy}^c - (\lambda_n^2 I_{yy} + A)p_{*i}] - \lambda_n^4 I_{xy}^2 p_{*i}^2}{[\lambda_n^4 I_{yy}^c - (\lambda_n^2 I_{yy} + A)p_{*i}](\lambda_n^2 I_{x\omega_D} + y_D A)p_{*i} + (\lambda_n^2 I_{y\omega_D} - x_D A)\lambda_n^2 I_{xy} p_{*i}^2} \end{bmatrix} \quad (28)$$

3 Numerical examples

The purpose of this section is to apply the present simplified theory in order to study the effects of approximations on the free vibration of thin-walled composite beams. In order to examine the applicability and the accuracy of the proposed method, the free vibration analysis for the simply supported composite thin walled beam with symmetric lamination are conducted and numerical results by the present study are compared with analytical solution reported by other researchers and those by FE procedures using ANSYS shell element.

3.1 Example 1

In this numerical example, the symmetric angle-ply I-beam with span length of 2 m, with various fiber directions are considered.

Dimensions of cross-section of I-beam are: both of flanges width and web height are 50 mm and all the beam walls are 2,08 mm thick. The flanges and web are assumed to be symmetrically laminated with respect to its mid-plane and formed by 16 plies with each of them 0,13 mm in thickness.

The mechanical properties of composite material are: $E_1 = 53,78$ GPa, $E_2 = 17,93$ GPa, $G_{12} = 8,96$ GPa, $\nu_{12} = 0,25$ and $\rho = 1968,9$ kg/m³.

The numerical values for sectional quantities, for different laminate stacking sequences, are presented in Tab. 1.

In the Table 2, the current theoretical predictions, for several fiber orientations, are correlated with results obtained from the exact stiffness matrix method of Kim et al. [14] as well as FE results of Vo et al. [17]. The present solution indicates good agreement with the analytical approach by Kim et al. [14] and Vo et al. [17] for all lamination schemes considered.

3.2 Example 2

A simply supported U beam with the length of $L = 12, 6$ and 4 m, tested by Cortinez and Piovan [18], was adopted for this investigation.

The bending-torsion coupled U-beam has a cross section, Fig. 2, formed by three equal laminates with four layers and total thickness $t = 30$ mm. The material properties are: $E_1 = 144$ GPa, $E_2 = 9,65$ GPa, $G_{12} = 4,14$ GPa, $\nu_{12} = 0,3$ and $\rho = 1389$ kg/m³.

The considered laminate schemes are /0/0/0/0/, /0/90/90/0/ and /45/-45/-45/45/.

The current theoretical predictions are correlated with results obtained by Cortinez and Piovan [18] in Tab. 3, for flexural-torsional vibration (xz plane), and in Tab. 4, for symmetric flexural vibration (xy plane).

Tabs. 3 and 4 show that natural frequencies by this study based on simplified theory are in a good agreement with the analytical solutions by Cortinez and Piovan.

3.3 Example 3

In order to have an additional comparison, for the case of simply supported composite thin-walled beam with span length of 10, 15 and 20 m and with open unsymmetrical cross-section shown in Fig. 3, the closed-form solutions presented in this paper are compared with a finite element results.

The finite element software ANSYS was used in this comparison, modeling the beam by means of elements SOLID 185.

The material properties are the same as previous example. The cross section is formed by four laminates with eight layers of equal thickness /75, 60, 45, 30/s.

The results are presented in Tab. 5.

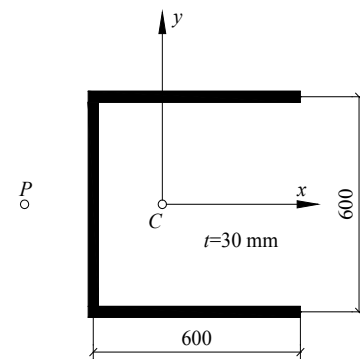

Figure 2 Cross section layout for Example 2

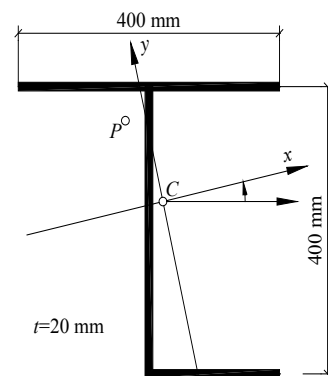

Figure 3 Cross section layout for Example 2

Table 1 Variation of sectional properties for different laminate stacking sequences

Sectional quantities	Stacking sequence						
	/0/16	/15/-15/4s	/30/-30/4s	/45/-45/4s	/60/-60/4s	/75/-75/4s	/90/-90/4s
$I_{xx}^c / \text{kN}\cdot\text{mm}^2$	$2,33248 \times 10^6$	$2,10736 \times 10^6$	$1,56480 \times 10^6$	$1,08322 \times 10^6$	$8,57074 \times 10^5$	$7,89597 \times 10^5$	$7,77639 \times 10^5$
$I_{yy}^c / \text{kN}\cdot\text{mm}^2$	$8,16067 \times 10^6$	$7,37302 \times 10^6$	$5,47475 \times 10^6$	$3,78985 \times 10^6$	$2,99865 \times 10^6$	$2,76257 \times 10^6$	$2,72073 \times 10^6$
$I_{\omega_D \omega_D}^c / \text{kN}\cdot\text{mm}^4$	$1,45780 \times 10^9$	$1,31710 \times 10^9$	$9,77997 \times 10^8$	$6,77011 \times 10^8$	$5,35671 \times 10^8$	$4,93498 \times 10^8$	$4,86024 \times 10^8$
$I_{ee}^c / \text{kN}\cdot\text{mm}^2$	$4,03151 \times 10^3$	$4,77099 \times 10^3$	$5,93268 \times 10^3$	$5,93279 \times 10^3$	$5,07283 \times 10^3$	$4,30859 \times 10^3$	$4,03151 \times 10^3$
A / mm^2				$3,12000 \times 10^2$			
I_{xx} / mm^4				$4,33708 \times 10^4$			
I_{yy} / mm^4				$1,51742 \times 10^5$			
I_{xy} / mm^4				0,0			
$I_{x\omega_D} / \text{mm}^5$				0,0			
$I_{y\omega_D} / \text{mm}^5$				0,0			
$I_{\omega_D \omega_D} / \text{mm}^6$				$2,71068 \times 10^7$			

Table 2 Natural frequencies (Hz) of a simply supported composite I-beam with $\pm\theta/4s$ angle-ply laminations

Mode	Formulation	Stacking sequence						
		/0/16	/15/-15/4s	/30/-30/4s	/45/-45/4s	/60/-60/4s	/75/-75/4s	/90/-90/4s
1	Ref. [14]	24,194	22,997	19,816	16,487	14,666	14,077	13,970
	Ref. [17]	24,198	23,001	19,820	16,490	14,668	14,079	13,972
	Present	24,194	22,997	19,816	16,488	14,666	14,077	13,970
2	Ref. [14]	35,233	36,247	37,051	30,827	27,420	26,319	26,119
	Ref. [17]	35,229	36,124	36,848	30,845	27,437	26,335	26,135
	Present	35,223	36,118	36,842	30,826	27,421	26,319	26,119
3	Ref. [14]	45,235	42,996	37,864	37,915	35,372	31,313	29,175
	Ref. [17]	45,262	43,022	37,073	35,171	32,254	29,985	29,172
	Present	45,235	42,997	37,051	35,165	32,249	29,980	29,167
4	Ref. [14]	96,726	91,940	79,225	65,916	58,633	56,278	55,850
	Ref. [17]	96,792	92,003	79,279	65,961	58,673	56,316	55,888
	Present	96,726	91,940	79,225	65,916	58,633	56,278	55,850
5	Ref. [14]	109,441	107,655	102,159	94,884	87,051	79,330	75,767
	Ref. [17]	109,485	107,538	100,710	90,605	82,109	77,289	75,798
	Present	109,410	107,465	100,641	90,543	82,053	77,236	75,746
6	Ref. [14]	180,616	171,678	147,938	123,085	109,484	105,087	104,287
	Ref. [17]	181,048	172,089	148,290	123,379	109,747	105,338	104,538
	Present	180,616	171,679	147,936	123,085	109,485	105,087	104,317

Table 3 Flexural-torsion frequencies (Hz) of U beams (xz plane)

Laminate	L / m	Formulation	Mode			
			1	2	3	4
/0/0/0/0/	12	Present study	9,85	38,73	51,67	86,76
		Cortinez and Piovan [18]	9,82	38,63	52,07	86,64
	6	Present study	38,73	153,80	201,94	344,01
		Cortinez and Piovan [18]	38,63	153,86	207,98	345,90
	4	Present study	86,76	344,02	438,99	765,09
		Cortinez and Piovan [18]	86,64	345,90	467,84	777,95
/0/90/90/0/	12	Present study	7,34	28,49	37,80	63,58
		Cortinez and Piovan [18]	7,30	28,35	38,09	63,41
	6	Present study	28,49	112,75	147,56	252,03
		Cortinez and Piovan [18]	26,02	112,50	151,95	252,76
	4	Present study	63,66	252,03	320,71	560,35
		Cortinez and Piovan [18]	63,41	252,76	341,73	568,31
/45/-45/-45/45/	12	Present study	4,48	14,12	17,47	29,71
		Cortinez and Piovan [18]	5,34	15,53	18,45	31,32
	6	Present study	14,12	51,38	65,96	112,35
		Cortinez and Piovan [18]	15,53	53,14	68,77	111,26
	4	Present study	29,71	112,81	142,47	246,39
		Cortinez and Piovan [18]	31,32	115,26	152,67	254,84

Table 4 Flexural frequencies (Hz) of U beams (νz plane)

Laminate	L / m	Formulation	Mode			
			1	2	3	4
/0/0/0/0/	12	Present study	22,19	88,40	197,56	347,95
		Cortinez and Piovan [18]	22,21	88,85	199,92	355,42
	6	Present study	88,40	347,94	763,14	1311,63
		Cortinez and Piovan [18]	88,85	355,42	799,69	1421,67
	4	Present study	197,56	763,14	1628,05	2709,10
		Cortinez and Piovan [18]	199,92	799,69	1799,30	3198,75
/0/90/90/0/	12	Present study	16,21	64,58	144,33	254,22
		Cortinez and Piovan [18]	16,22	64,89	146,00	259,56
	6	Present study	64,58	254,22	557,53	958,23
		Cortinez and Piovan [18]	64,89	259,56	584,01	1038,24
	4	Present study	144,33	557,53	1189,40	1979,18
		Cortinez and Piovan [18]	146,00	584,01	1314,02	2336,04
/45/-45/-45/45/	12	Present study	7,17	28,54	63,78	112,35
		Cortinez and Piovan [18]	7,18	28,70	64,58	114,82
	6	Present study	28,54	112,39	241,75	423,47
		Cortinez and Piovan [18]	28,70	114,81	258,33	459,28
	4	Present study	63,79	248,39	525,63	913,52
		Cortinez and Piovan [18]	64,58	258,33	581,24	1033,38

Table 5 Flexural-torsion frequencies (Hz) of beam studied as Example 3 for stacking sequence /75/60/45/30/s

External mode	$L=10\text{ m}$			$L=15\text{ m}$			$L=20\text{ m}$		
	Present study	Ansys	Error / %	Present study	Ansys	Error / %	Present study	Ansys	Error / %
$n = 1$	4,51	4,51	0,00	2,08	2,05	1,46	1,18	1,16	1,72
	7,61	8,19	7,08	4,04	4,14	2,41	2,42	2,41	0,41
	11,04	11,08	0,36	5,43	5,91	8,12	3,65	4,14	11,83
$n = 2$	15,89	16,18	1,79	7,66	7,74	1,03	4,51	4,50	0,22
	24,40	24,84	1,77	12,00	12,67	5,29	7,60	8,14	6,63
	33,33	33,53	0,60	15,89	16,15	1,61	9,48	9,60	1,25
$n = 3$	42,64	40,89	4,28	19,22	18,80	2,23	11,04	11,05	0,09
	52,50	52,08	0,81	24,40	24,80	1,61	14,62	15,25	4,13
	57,29	56,85	0,77	26,81	27,07	0,96	15,89	16,14	1,55

4 Conclusion

In this paper an approximate analytical method for determining natural frequencies was developed for thin-walled beams with arbitrary open cross-section made of laminated composites, symmetric with respect to their mid plane. In each laminate, the fibers are continuous, unidirectional, and directed in an arbitrary orientation with respect to the longitudinal axis of the element. All of the possible vibration modes including axial mode, and fully coupled flexural-torsional modes are included in the analysis. At the example of simply supported beam, the simplified analysis procedure has been validated by comparing the results based on the simplified method with other results reported in literature and by comparing with the results obtained from finite element analysis using ANSYS. It is shown that approximations introduced have a small effect on the accuracy of results. The model presented is found to be appropriate and efficient in analyzing free vibration problem of a thin-walled laminated composite beam, so the method is useful

- to define a quick approximate method;
- to execute simple preliminary design considerations or fast final general checks of accuracy.

Although the paper deals only with simple support conditions it may be supposed that it is reasonable enough to extend all conclusions to the beams with other boundary conditions.

Acknowledgements

The present work has been supported by The Ministry of Education and Science of the Republic of Serbia (Project No. ON174027 and TR 36043).

5 References

- [1] Back, S. Y.; Will, K. M. Shear-flexible thin-walled element for composite I-beams. // *Engineering Structures*. 30, 5 (2008), pp. 1447-1458.
- [2] Banerjee, J. R.; Williams, F. W. Exact dynamic stiffness matrix for composite Timoshenko beams with applications. // *Journal of Sound and Vibration*. 194, 4(1996), pp. 573-585.
- [3] Cardoso, B. J.; Valido, A. J. Cross-section optimal design of composite laminated thin-walled beams. // *Computer and Structures*. 89, 11-12(2011), pp. 1069-1076.
- [4] Chen, H. H.; Hsiao, K. M. Quadruply coupled linear free vibrations of thin-walled beams with a generic open section. // *Engineering Structures*. 30, 5(2008), pp. 1319-1334.
- [5] Kim, N. I.; Shin, D. K.; Kim, M. Y. Improved flexural-torsional stability analysis of thin-walled composite beam and exact stiffness matrix. // *International Journal of Mechanical Sciences*. 49, 8(2007), pp. 950-969.
- [6] Lee, J.; Lee, S. Flexural-torsional behavior of thin-walled composite beams. // *Thin-Walled Structures*. 42, 9(2004), pp. 1293-1305.
- [7] Piovan, M. T.; Cortinez, V. H. Mechanics of shear deformable thin-walled beams made of composite

- materials. // *Thin-Walled Structures*, 45, 1 (2007), pp. 37-62.
- [8] Qin, Z.; Librescu, L. On a shear-deformable theory of anisotropic thin-walled beams: further contribution and validations. *Composite Structures*. 56, 4(2002), pp. 345-358.
- [9] Rajasekaran, S. Optimal laminate sequence of non-prismatic thin-walled composite spatial members of generic section. // *Composite Structures*. 70, 2(2005), pp. 200-211.
- [10] Sapountzakis, E. J.; Mokos, V. G. 3-D beam element of composite cross section including warping and shear deformation effects. // *Computer and Structures*. 85, 1-2(2007), pp. 102-116.
- [11] Vo, T. P.; Lee, J. On sixfold coupled buckling of thin-walled composite beams. // *Composite Structures*. 90, 3(2009), pp. 295-303.
- [12] Banerjee, J. R. Free vibration of axially loaded composite Timoshenko beams using the dynamic stiffness matrix method. // *Computer and Structures*. 69, 2(1998), pp. 197-208.
- [13] Banerjee, J. R.; Su, H. Dynamic stiffness formulation and free vibration analysis of a spinning composite beam. // *Computer Structures*. 84, 19-20(2006), pp. 1208-1214.
- [14] Kim, N. I.; Shin, D. K.; Park, Y. S. Dynamic stiffness matrix of thin-walled composite I beam with symmetric and arbitrary laminations. // *Journal of Sound and Vibration*. 318, 1-2(2008), pp. 364-388.
- [15] Machado, S. P.; Cortínez, V. H. Free vibration of thin-walled composite beams with static initial stresses and deformations. // *Engineering Structures*, 29, 3(2007), pp. 372-382.
- [16] Moon-Young, K.; Nam I. K.; Hee-Taek, Y. Exact dynamic and static stiffness matrices of shear deformable thin-walled beam-columns. // *Journal of Sound and Vibration*. 267, 1(2003), pp. 29-55.
- [17] Vo, T. P.; Lee, L.; Lee, K. On triply coupled vibrations of axially loaded thin-walled composite beams. // *Computer Structures*. 88, 3-4(2010), pp. 144-153.
- [18] Cortínez, V. H.; Piovan, M. T. Vibration and buckling of composite thin-walled beams with shear deformability. // *Journal of Sound and Vibration*. 258, 4(2002), pp. 701-723.
- [19] Prokić, A. On triply coupled vibration of thin-walled beams with arbitrary cross-section. // *Journal of Sound and Vibration*. 279, 3-5(2005), pp. 723-737.
- [20] Prokić, A. On fivefold coupled vibration of Timoshenko thin-walled beams. // *Engineering Structures*. 28, 1(2006), pp. 54-62.
- [21] Jones, R. M. *Mechanics of composite materials*. Hemisphere Publishing Corporation, New York, 1975.

Authors' addresses

Aleksandar Prokić, Professor Dr. Sc.
University of Novi Sad, Faculty of Civil Engineering
Kozaračka 2a
24000 Subotica, Serbia
Tel.: +381 63 532 27 09
E-mail: aprokic@eunet.rs

Radomir Folić, Professor Emeritus Dr. Sc.
University of Novi Sad, Faculty of Technical Sciences
Trg Dositeja Obradovića 6
21000 Novi Sad, Serbia
Tel.: +381 63 102 80 59
E-mail: folic@uns.ac.rs

Ilija Miličić, Assistant Professor Dr. Sc.
University of Novi Sad, Faculty of Civil Engineering
Kozaračka 2a
24000 Subotica, Serbia
Tel.: +381 64 222 12 91
E-mail: milicic@gf.uns.ac.rs

Appendix

The coefficients in the frequency equation (27) are:

$$\begin{aligned}
 a &= -2 \left(\lambda_n^2 I_{y\omega_D} - x_D A \right) \left(\lambda_n^2 I_{x\omega_D} + y_D A \right) \lambda_n^2 I_{xy} + \left(\lambda_n^2 I_{x\omega_D} + y_D A \right)^2 \left(\lambda_n^2 I_{yy} + A \right) + \left(\lambda_n^2 I_{\omega_D \omega_D} + I_D \right) \lambda_n^4 I_{xy}^2 + \left(\lambda_n^2 I_{y\omega_D} - x_D A \right)^2 \left(\lambda_n^2 I_{xx} + A \right) - \left(\lambda_n^2 I_{xx} + A \right) \left(\lambda_n^2 I_{yy} + A \right) \left(\lambda_n^2 I_{\omega_D \omega_D} + I_D \right), \\
 b &= - \left(\lambda_n^2 I_{x\omega_D} + y_D A \right)^2 \lambda_n^4 I_{yy}^c - \left(\lambda_n^2 I_{\omega_D \omega_D} + I_{ee}^c \right) \lambda_n^6 I_{xy}^2 - \left(\lambda_n^2 I_{y\omega_D} - x_D A \right)^2 \lambda_n^4 I_{xx}^c + \lambda_n^2 \left(\lambda_n^2 I_{xx} + A \right) \left(\lambda_n^2 I_{yy} + A \right) \left(\lambda_n^2 I_{\omega_D \omega_D} + I_{ee}^c \right) + \lambda_n^4 \left[I_{yy}^c \left(\lambda_n^2 I_{xx} + A \right) + I_{xx}^c \left(\lambda_n^2 I_{yy} + A \right) \right] \left(\lambda_n^2 I_{\omega_D \omega_D} + I_D \right), \\
 c &= -\lambda_n^6 \left[I_{yy}^c \left(\lambda_n^2 I_{xx} + A \right) + I_{xx}^c \left(\lambda_n^2 I_{yy} + A \right) \right] \left(\lambda_n^2 I_{\omega_D \omega_D} + I_{ee}^c \right) - \left(\lambda_n^2 I_{\omega_D \omega_D} + I_D \right) \lambda_n^8 I_{xx}^c I_{yy}^c, \\
 d &= \left(\lambda_n^2 I_{\omega_D \omega_D} + I_{ee}^c \right) \lambda_n^{10} I_{xx}^c I_{yy}^c.
 \end{aligned}$$